

SADT-100WM SADT-101WM SADT-102WM

Wall Mount Adaptor

Summary

SADT-100WM/101WM/102WM, which is used when installing the SmartDome camera and Anti-Vandal camera on the wall, are solid and durable products.



Features

SADT-100WM SADT-101WM

- Indoor/Outdoor Use
- Solid Structure
- Aluminum Material

SADT-102WM

- Indoor/Outdoor Use
- Solid Structure
- Aluminum Material
- Gasket provides Waterproof Function
- Screws included, for Camera Mounting

Specifications

Model	SADT-100WM	SADT-101WM	SADT-102WM
Weight	800g		
Operating Temperature	-40 ~ +50°C	40 ~ +60°C	
Operating Humidity	0~100% RH		
Accessory	Gasket 1EA Back Plate 1EA Screw(FH M3xL6) 6EA Screw(PH M4xL8) 2EA		
		Screw(PM M4xL8) 2EA	Screw(PM M4xL8) 4EA

Installation

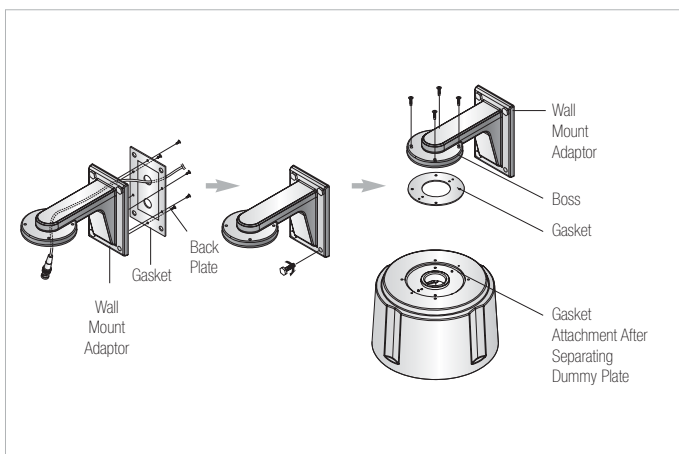

Dimensions (unit:mm)

SADT-100WM

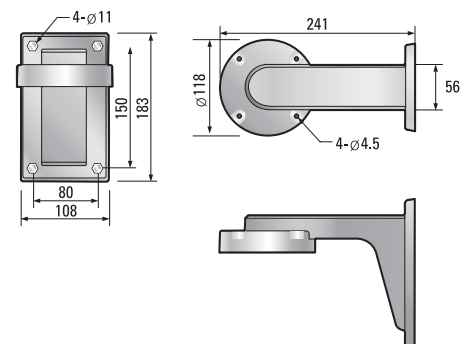

SADT-101WM/102WM

